

SGM450

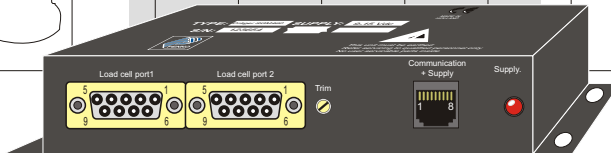

SGM460



SGM500

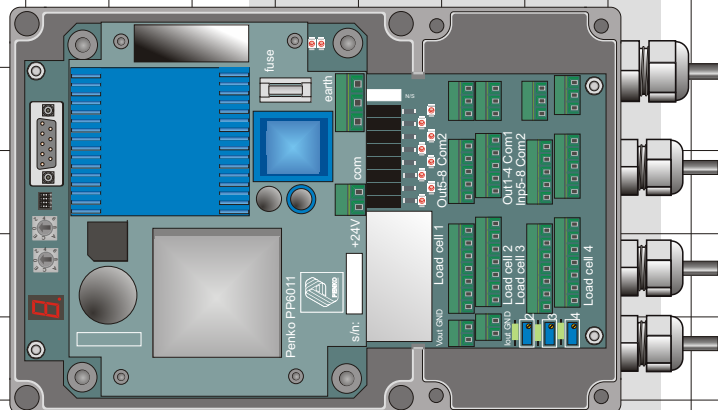

SGM600

Weigh Amplifier/Conditioner type SGM

IMPORTANT SAFETY INFORMATION

READ THIS PAGE FIRST!

Penko Engineering manufactures and tests its products to meet all applicable national and international standards. It is vital that this instrument is correctly installed, used, and maintained to ensure it continues to operate to its optimum specification.

The following instructions must be adhered to and incorporated into your safety programme when installing, using, and maintaining Penko products. Failure to follow the recommended instructions can affect the system's safety and may increase the risk of serious personal injury, property damage, damage to this instrument and may invalidate the product's warranty.

- Read the instructions fully prior to installing, operating, or servicing the product. If this Instruction Manual is not the correct manual for the Penko product you are using, telephone 0031(0)318-525630 for a replacement copy. Keep this Instruction Manual in a safe place for future reference.
- If you do not fully understand these instructions, contact your Penko representative for clarification.
- Pay careful attention to all warnings, cautions, and instructions marked on and supplied with the product.
- Inform and educate your personnel about the correct installation, operation, and maintenance procedures for this product.
- Install your equipment as specified in the installation instructions of the appropriate Instruction Manual and as per applicable local and national codes. Connect all products to the proper electrical sources.
- To ensure correct performance, use qualified personnel to install, operate, update, program, and maintain the product.
- When replacement parts are required, ensure that qualified technicians use replacement parts specified by Penko. Unauthorized components and procedures can affect the product's performance and may affect the continued safe operation of your processes. The use of non-specified 'look-alike' substitution parts may result in the risk of fire, electrical hazards, or improper operation.
- Ensure that all equipment doors are closed and protective covers are in place, except when maintenance is being performed by qualified persons, to prevent electrical shock and personal injury.

WARNING

ELECTRICAL SHOCK HAZARD

Installing cable connections and servicing this instrument require access to shock hazard level voltages which can cause death or serious injury.

Disconnect separate or external power sources to relay contacts before commencing any maintenance.

The electrical installation must be carried out in accordance with CE directions and/or any other applicable national or local codes.

Unused cable conduit entries must be securely sealed by non-flammable blanking plates or blind grommets to ensure complete enclosure integrity in compliance with personal safety and environmental protection requirements.

To ensure safety and correct performance this instrument must be connected to a properly grounded, three-wire power source.

Proper relay use and configuration is the responsibility of the user.

Do not operate this instrument without the front cover being secured. Refer any installation, operation or servicing issues to qualified personnel.

WWW.PENKO.COM

Penko is an ETC Company

e-mail: info@penko.com

Contents

1. List of tables
2. System description
 - 2.1 Communication parameters
 - 2.2 Command summary
 - 2.2.1 Multi-drop support
 - 2.2.2 System diagnostics
 - 2.2.3 Weigher operation
 - 2.2.4 Peak and valley detection
 - 2.2.5 Virtual display support
 - 2.2.6 Remote i/o support (sgm500 only)
 - 2.2.7 Set point operation
 - 2.2.8 Analog output
 - 2.2.9 Saving the device configuration
- 3.1 Wiring connections SGM450
- 3.2 Station number and Baudrate settings
- 3.3 Wiring connections SGM500
- 3.4 Wiring connections SGM600

1. List of tables

Table A Baudrate settings SGM450
Table B Baudrate settings SGM500
Table C Multi-drop commands
Table D Diagnostic commands
Table E 'IS'-bit patterns
Table F Weigher commands
Table G Long string status bit field
Table H Pre-Calibration commands
Table I Calibration commands
Table J Preset tare support
Table K Zero-tracking commands
Table L Stable / No-motion commands
Table M Auto-transmit commands
Table N Peak and valley commands
Table O Virtual display commands
Table P Remote I/O commands
Table Q Set point commands
Table R Live channel indexes
Table S Analog output commands
Table T Actual temperature
Table U 'WP'-parameter list

2. System description

This document describes the basic features for the Penko SGM/PC. This compact state of the art design allows for easy implementation of weighing applications targeting vertical markets.

It features fast sample rates which can be used to monitor fast industry processes like dosing. As the core storage is based on Flash Rom technology, easy adaption of software is provided. The on-board in-and outputs (SGM500 only) can be controlled by the weighing operation or by the remote control application through the easy communication protocol. Protocol format: 8 databits, 1 stopbit, no parity.

Key features SGM 450:

- Sampling rate up to 50 sample/sec,
- 6-wire loadcell connection,
- unit supplied with matching load-cell,
- RS-422 interface or RS232 interface,
- Multi-drop communication protocol allows up to 63 units (RS422 only),
- Plug-in replacement for SAI-PC,
- Traceable access code for certified operation,
- In-system weight rounding provides display ready information,
- Internal easy up datable Flash ROM,
- 12-24V DC supply.

Key features SGM 460:

- Sampling rate up to 50 sample/sec,
- 6-wire loadcell connection, max 2 loadcells
- Excitation trim for corner correction,
- unit supplied with matching load-cell,
- RS232 interface, 9600baud
- Plug-in replacement for SAI-PC with RS232,
- Internal temperature information,
- Traceable access code for certified operation,
- In-system weight rounding provides display ready information,
- Internal easy up datable Flash ROM,
- 9-18V DC supply.

Key features SGM500:

- Fast sampling rate, 1000 sample/sec,
- 6-wire loadcell connection,
- unit supplied with matching load-cell,
- 4 on-board outputs,
- 4 on-board inputs,
- 4-wire RS-485 interface,
- Multi-drop communication protocol allows up to 255 units,
- Plug-in replacement for SAI-PC,
- Traceable access code for certified operation,
- In-system weight rounding provides display ready information,
- Internal easy up datable Flash ROM,
- 24V DC supply.

Key features SGM600:

Fast sampling rate, 1000 sample/sec,
4 x 6-wire loadcell connection,
unit supplied with matching load-cell,
up to 8 on-board outputs,
up to 8 on-board inputs,
analog output 0..10V, 0..5V, -5..+5V, -10..+10V or 4..20mA, 0..20mA, 0..24mA
4-wire RS-422 interface,
Multi-drop communication protocol allows up to 255 units,
Plug-in replacement for SAI-PC,
Traceable access code for certified operation,
In-system weight rounding provides display ready information,
Internal easy up datable Flash ROM,
230V AC supply.

2.1 Communication parameters

Using the 8 internal dipswitches the protocol parameters can be set. All configurations will use a 8/N/1-format, ie 8 data bits, no parity, 1 stop bit. Available data rates (configurational through onboard dipswitches) are listed in table a baudrate settings. The SGM460 is fixed to 9600 baud.

DIP 7	DIP 8	Baudrate
close	close	9600
open	closed	19k2
closed	open	38k4
open	Open	115k2

Table A: Baudrate settings SGM450

Dip 1	Dip 2	Baudrate
open	open	9600
open	closed	19k2
closed	open	38k4
Closed	closed	115k2

Table B Baudrate settings SGM500

SGM500/600

Even at the relative slow communication rate of 9600 baud it is possible to get a 100 samples per seconds using the special auto-transmit command. Higher data rates are particular useful in systems with multi-drop support as it allows for a great elimination of the protocol addressing overhead.

DIP 2 Baudrate

2.2 Command summary

The easy ASCII-command set, which is also available in the SAI4/6-PC indicator range, is available for this application. Units of SGM/PC and SAI/PC can be intermixed on the same system allowing for a flexible implementation that will suite the best needs of the user, using a display unit only where needed. Command input processing on the SGM/PC is based on a circular buffer, in contrast to the line buffer approach which was used on the SAI4/6-PC. When using the SGM/PC in a multi-drop environment, it is therefore allowed to directly transmit multiple commands without waiting for the response. Host response implementation should then be made capable of interpreting multiple commands. This feature allow for faster communication as the figure below illustrates.

Line buffer implementation	Send:	GN		GG	
	Receive:		N+01000.		G+01100.
Circular buffer implementation	Send:	GN	GG		
	Receive:		N+01000.		G+01100.

Figure A Line buffer vs. circular buffer

This feature is particular interesting when using the system in a multi-drop configuration as it is now possible to directly select the device and issue the requested command. In this case there is no need to wait for the OK-response on the OPen command. The OK-response, however, is send by the device so your input/response string handling should be capable of processing it in combination with the reading of the value.

Due to limited resources on SAI/PC and AMI/PC indicators, this feature is not available on these devices. Therefore when mixing SGM/PC- and SAI/PC- use of this enhancement is not allowed.

2.2.1 Multi-drop support (SGM450/500 &600 only)

Typical operation for the SGM/PC unit is in an environment where multiple units are connected over a RS-422 serial communication bus system. The open and close commands provide for a device selection mechanisms that allows the implementation of a layered protocol stack. A connection to the required device is opened using the OP-command specifying the number of the unit as configured using the two rotating switches. Beware that the switches provide a hexadecimal interface while the actual OP-command requires the address to be in a decimal notation. To verify the established link a OP-command can be issued with out any parameters. The device currently selected will reply by sending a O+00xxxÆ-reply where xxx is the number of the device.

By detection of any open command, all units perform a close operation. This will allow for an enhancement in the communication speed as it is no longer needed to send a CL-command. Up to 255 devices, using a special RS-422 interface circuit, can be connected allowing for vast system implementations.

Command:	Operation:	Response:
OP	open connection	O+00001/OK/ERR
CL	close all connections	no response

Table C: Multi-drop commands

Multi-drop support is only available when the device id selection is set to a number not equal to zero. When setting the device number to zero an omni-mode is activated where the device will no longer listen to the OP-and CL-commands and will always respond to any system request.

2.2.2 System diagnostics

Use the system diagnosis functions to get information about the device type and the internal S/W revision of the device. Use the device identifier and the S/W version number to detect the availability of special command required by your application.

Command:	Operation:	Response:
IV	info version	V:0110
ID	info device	D:0105 (SGM500) D:0106 (SGM450) D:0107 (SGM600) D:010A (SGM460)
IS	info status	S:000000

Table D: Diagnostic commands

Mask	Description
1	Signal stable
2	Zero action performed
4	Tare active
8	Total, not supported
16	Menu, not supported
32	Select, not supported
64	Output 1 active (Sgm450 always 0)
128	Output 2 active (Sgm450 always 0)

Table E: 'IS'-bit patterns

simulated option leds as available on these devices. The reply consist of two 3 digit decimal values which reflect the status of the option leds and there flashing state. On the SGM/PC the flashing state is not supported and the right 3 digits will therefore always return 000. The left 3 digits use the mapping from the following table, where unsupported bits always read 0.

2.2.3 Weigher operation

Basic weigher operation is performed through the commands listed below. Easy commands are available to zero or tare the weigher, reset the zero or tare, retrieve the current gross, net and tare weight

Command:	Operation:	Response:
SZ	set system zero	OK/ERR
RZ	reset system zero	OK/ERR
ST	set tare	OK/ERR
RT	reset tare	OK/ERR
FL	change s/w damping factor	F+00008./OK/ERR
GN	get net value	N+01000.
GG	get gross value	G+01100.
GT	get tare value	T+00100.
GF	get fast net value	F+01000.
GS	get A/D sample	S+65535
GW	get weight	W+00100+011005109
LW	long weight info	W+00100+011005109
LN	long net info	N+00100+0010051cc
LF	long fast weight info	F+00100+011005109

Table F: Weigher commands

Within the long command strings a hexadecimal status field is available which uses the following bitmapped status indicators for reflecting the current device status. The mapping is compatible with the SAI/PC and AMI/PC-devices. The long reply commands also provide support for checksum validation by simply adding all characters in the string up, not including the checksum characters, and taking its 1s complement, ie inverting it.

Bit	Description
0x01	Output 1 active (SGM450/460 always 0)
0x02	Output 2 active (SGM450/460 always 0)
0x04	Weight above maximum load
0x08	Signal in zeroing range
0x10	Signal stable
0x20	Zero setting performed
0x40	Tare active
0x80	Bad system calibration

Table G: Long string status bit field

Note: The use of the GW-command is not recommended for new designs, use the LW command instead.

2.2.3.1 Remote precalibration support for SGM460 & SGM450 (version 1.35 & higher)

Through the use of the remote precalibration interface the user application can provide a tailored end-user interface. As this is not a regular performed operation, or at least should not be, some handicaps are built in to prevent accidental operation. The table below lists the commands available for the calibration operation.

Command:	Operation:	Response:
CE	calibration enable/query traceable access code	OK/ERR
ZP	polarity: uni=0 or bi=1 polair	P+00000./OK/ERR
ZE	excitation frequency 0/250/500/1000Hz	E+00250./OK/ERR
ZG	loadcell voltage 0.5/1.0/1.5/2.0mV/V	G+00020./OK/ERR
ZO	dead load offset	O+00283./OK/ERR
ZC	ADC conversion rate	C+00200./OK/ERR
ZR	recall,of factory settings	OK/ERR
ZS	precalibration save	OK/ERR

Table H: Calibration commands

The pre-calibration interface features a traceable access code as is required for certified operations. The altering of the pre-calibration relevant data is only enabled after providing the correct access code.

To perform a precalibration the following steps must be made:

Step	Command	Description
1	CE	Query the current traceable access code.
2	CE xxxxx	Enable the precalibration commands, where xxxxx is the traceable access code returned
3	ZP 1	Select bi-polair mode, 0mV => 32767 ADC-parts
4	CE xxxxx	Enable the precalibration commands, where xxxxx is the traceable access code found earlier
5	ZE 0	Select DC excitation mode
6	CE xxxxx	Enable the precalibration commands, where xxxxx is the traceable access code found earlier
7	ZG 25	Select 2.5mV/V loadcell
8	CE xxxxx	Enable the precalibration commands, where xxxxx is the traceable access code found earlier.
9	ZO 282	Correct dead load.
10	CE xxxxx	Enable the precalibration commands, where xxxxx is the traceable access code found earlier.
11	ZS	Save the precalibration. The traceable access code is now incremented and stored with the calibration data.

During the calibration it is very handy to provide a visual feedback by showing the user the current raw A/D sample using the GS-command.

Note that for certified operation it is required that the user interface provides a read back only facility for the traceable access code.

2.2.3.2 Remote calibration support

Through the use of the remote calibration interface the user application can provide a tailored end-user interface. As this is not a regular performed operation, or at least should not be, some handicaps are built in to prevent accidental operation. The table below lists the commands available for the calibration operation.

Command:	Operation:	Response:
CE	calibration enable/query traceable access code	OK/ERR
CZ	calibrate zero	OK/ERR
CG	calibrate gain	G+02000./OK/ERR
CS	calibration save	OK/ERR
CM	system maximum load value	M+02000./OK/ERR
DS	display step size	S+00002/OK/ERR
DP	display decimal point setting	P+00003/OK/ERR

Table 1: Calibration commands

The calibration interface features a traceable access code as is required for certified operations. The altering of the calibration relevant data is only enabled after providing the correct access code. Display step size and decimal point settings are considered to be calibration data and so there access is also protected by the traceable access code, as is the system maximum load value.

To perform a calibration the following steps must be made:

Step	Command	Description
1	CE	Query the current traceable access code.
2	CE xxxxx	Enable the zero calibration, where xxxxx is the traceable access code returned
3	CZ	Unload the weigher and perform a zero calibration
4	CG	Retrieve the previous gain calibration value by issuing the gain command without a value. This provides a neat user interface action, also this may allow usage of a fixed reference value. Optionally read the user input for a new calibration value.
5	CE xxxxx	Enable the gain calibration, where xxxxx is the traceable access code found earlier
6	CG	Load the weigher with the reference load and issue the gain command.
7	GG	Verify the calibration by reading the gross weight value and presenting it to the operator. If the operator decides that the calibration is not sufficient provide a path to repeat step 1 through 7
8	CE xxxxx	Enable the saving of the calibration, where xxxxx is the traceable access code found earlier.
9	CS	Save the calibration. The traceable access code is now incremented and stored with the calibration data.

During the calibration it is very handy to provide a visual feedback by showing the user the current raw A/D sample using the GS-command.

Similar to the calibration CG-command, the CM-, DP-and DS-commands need to be proceeded by CE xxxxx-sequence when altering these parameters. There is no need for the enabling sequence when only performing a read back operation, just provide the command only. Note that for certified operation it is required that the user interface provides a read back only facility for the traceable access code.

2.2.3.3 Preset tare support

Preset tare is supported through two commands. The PT-commands allows read-back and setting of the preset tare while the PS-command merely activates the previously configured preset tare value. Read-back operation of the preset tare is provided through the use of the PT-command without any parameters.

Command:	Operation:	Response:
PT	get/set preset tare	P+02000./OK/ERR
PS	activate preset tare	OK/ERR

Table J: Preset tare support

2.2.3.4 Zero-tracking support

Preventing the influence of residual dirt on the loadcell, programmable zero-tracking operation is provided through the use of the commands in the table below. Zero-tracking allow the weigher to correct small amounts of offset signal in a small range around the calibration zero level.

Read-back of the parameters is provided through the sending of the command without a value.

Command:	Operation:	Response:
TR	zero-tracking range	R+00010.
TS	zero-tracking step size	S+00003.
TT	zero-tracking stable time	T+01000.

Table K Zero-tracking commands

2.2.3.5 Stable / No-motion support

In order to configure the stable/no-motion parameters the following commands are provided. The NT-command specifies the time the input signal needs to be within the specified range. The range can be configured using the NR-command.

Read-back of the parameters is provided through the sending of the command without a value.

Command:	Operation:	response:
NR	no-motion range	R+00010./OK/ERR
NT	no-motion time	T+00500/OK/ERR

Table L: Stable / No-motion commands

2.2.3.6 Fast data transfers

To support the research on fast processes the auto-repeat commands are provided. They provide a constant stream of data at the highest possible data rate, depending on the selected baudrate and size of the string to respond with. Using the short strings, already a sample rate of up to 100 samples/sec can be provided at 9600 baud.

Command:	Operation:	Response:
SN	start auto-transmit net	N+01000.
SG	start auto-transmit gross	G+01100.
SF	start auto-transmit fast net	F+01000.
SW	start auto-transmit weight	W+01000+01100SSCC
SP	start auto-transmit peak	P+02000.
SV	start auto-transmit valley	V-00150.

Table M: Auto-transmit commands

Note that when using the long string command the repeat time is doubled as it takes twice as long to transmit the reply string.

2.2.4 Peak and valley detection

By exploiting the fast internal sample rate of 1000 samples/second, applications which need for a fast peak or valley detection can be supported by the commands in the table. Before starting a peak or valley detection you should reset the peak and valley storage by issuing the RP and RV commands. Reading of the peak and valley values can be accomplished by sending the commands GP and/or GV.

Command:	Operation:	Response:
RP	reset peak	OK/ERR
RV	reset valley	OK/ERR
GP	get peak value	P+02000.
GV	get valley value	V-00150.

Table N: Peak and valley commands

2.2.5 Virtual display support

To aid the development of your application the SGM/PC provides direct display values which feature automatic support of slower display updates, special display damping actions and a programmable zero-suppressing range. Read back of the parameters is provided through the sending of the command without a value.

Command:	Operation:	Response:
DR	display rate	R+00100. /OK/ERR
DZ	display zero suppression range	Z+00010. /OK/ERR
DA	display damping active range	A+00100. /OK/ERR
DD	display damping	D+00008/OK/ERR
DS	display step size	S+00002/OK/ERR
DP	display point position	P+00003/OK/ERR

Table O: Virtual display commands

Additional commands are provided to support the setting of a decimal point position and a display step size. These commands, DS and DP, are part of the calibration setting and are protected by the traceable access code feature.

2.2.6 Remote I/O support (SGM500/600 only)

The inputs and outputs of the device can be used for generic input and output, while the outputs can be configured to use the set point level operations. The commands in the table below are provided to obtain access to the I/O system.

Replay and responses are provided in a bitmapped manner which allows a 0 or 1 for specifying false or true. A typical command would look like:

SGM500: IO 0101

SGM600: IO 01010101

Command:	Operation:	Response:
IN	read input status	IN:0011
IO	read/modify output status	IO:0101/OK/ERR
IM	read/modify manual status	IM:1100/OK/ERR
IL	read level status	IL:1100/OK/ERR

Table P: Remote I/O commands

In order to control the outputs from the host application the outputs must be configured using the IM-command specifying the output bit pattern for all host controlled outputs. Then using the IO-command the new output bit pattern can be written. When reading back the output status using the IO-command the set point status is still returned.

2.2.7 Set point operation (SGM500/SGM600 only)

The 4/8 on-board set points can be configured in the same manner as would be done on a SAI/PC-indicator device. They feature a per channel programmable live channel selection, programmable level setting, programmable minimum/maximum operation and a programmable hysteresis setting. All set point settings can be stored internally to provide for a save operation from power-on. Read-back of the parameters is provided through the sending of the command without a value.

Command:	Operation:	Response:
S1	get/set setpoint 1	1+01500./OK/ERR
S2	get/set setpoint 2	2+02000./OK/ERR
S3	get/set setpoint 3	3+02500./OK/ERR
S4	get/set setpoint 4	4+03000./OK/ERR
H1	get/set setpoint 1 hysteresis	1+00100./OK/ERR
H2	get/set setpoint 2 hysteresis	2+00100./OK/ERR
H3	get/set setpoint 3 hysteresis	3+00100./OK/ERR
H4	get/set setpoint 4 hysteresis	4+00100./OK/ERR
A1	get/set setpoint 1 action	1+00001/OK/ERR
A2	get/set setpoint 2 action	2+00001/OK/ERR
A3	get/set setpoint 3 action	3+00001/OK/ERR
A4	get/set setpoint 4 action	4+00001/OK/ERR
SS	save level setup	OK/ERR

Table Q: Set point commands

Selection of live channels is accomplished by the Ax-command and provides access to one of the live channels number using the table below.

Channel	Description
0	Fast gross weight
1	Fast net weight
2	Display gross weight
3	Display net weight
4	Peak weight
5	Valley weight
6	Active tare weight

Table R: Live channel indexes

2.2.8 Analog output (SGM600 only)

The analog output can be configured with commands as shown in table R. The low level weight (command AL) is the analog minimum level 0V or 4mA . The high level weight (command AH) is the analog maximum level 10V or 20mA. All settings can be stored internally to provide for a save operation from power-on. Read-back of the parameters is provided through the sending of the command without a value.

Table S: Analog output commands

Command:	Operation:	Response:
AL	get/set low level	L+01500./OK/ERR
AH	get/set high level	H+02000./OK/ERR
AA	get/set action	A+00001/OK/ERR
AS	save analog parameters	OK/ERR

2.2.9 Actual temperature of SGM (SGM460 only)

The inside temperature of the SGM460 can be read out with the command TC.

TC	get actual temperature in celsius	C+00025
----	-----------------------------------	---------

Table T: Actual temperature

2.2.9 Saving the device configuration

The device configuration consists of 3 sets of parameters, calibration parameters, indicator parameters and set point parameters. Altering and saving of the calibration requires a complex set of operations as is described by the procedure in section about remote calibration support. Set point parameters can be saved through the SS-command and do not need a lock \-out operation. Similar the indicator parameters can be saved at any time using the WP-command, Write Parameters. Parameters which will be saved are listed in the table below.

Parameter:	Description:
FL	filter setting
DD	display damping
DA	display damping active range
DZ	display zero suppressing range
TR	zero-tracking range
TS	zero-tracking maximum step
TT	zero-tracking time interval
NR	no-motion range
NT	no-motion time

Table U: 'WP'-parameter list

3.1 WIRING CONNECTIONS SGM450

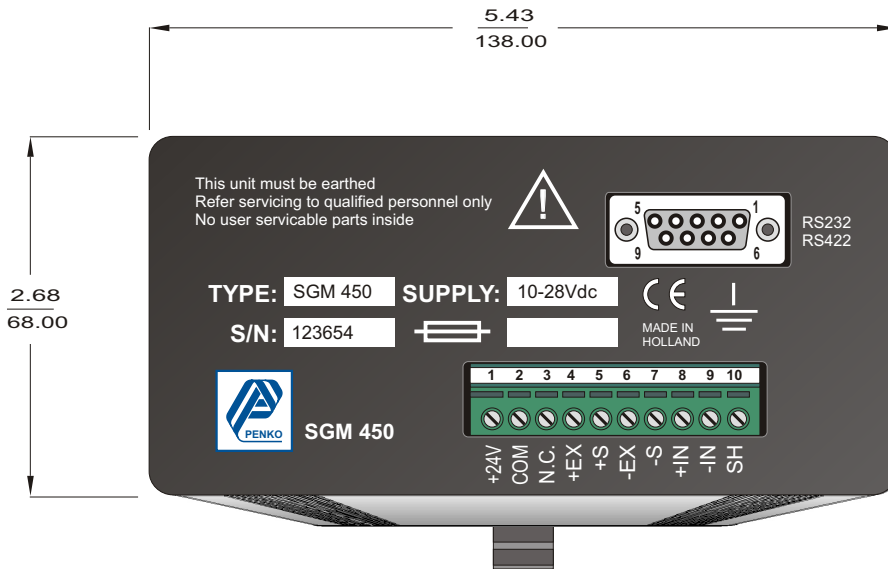

CABINET FOR MOUNTING ON DIN-RAIL

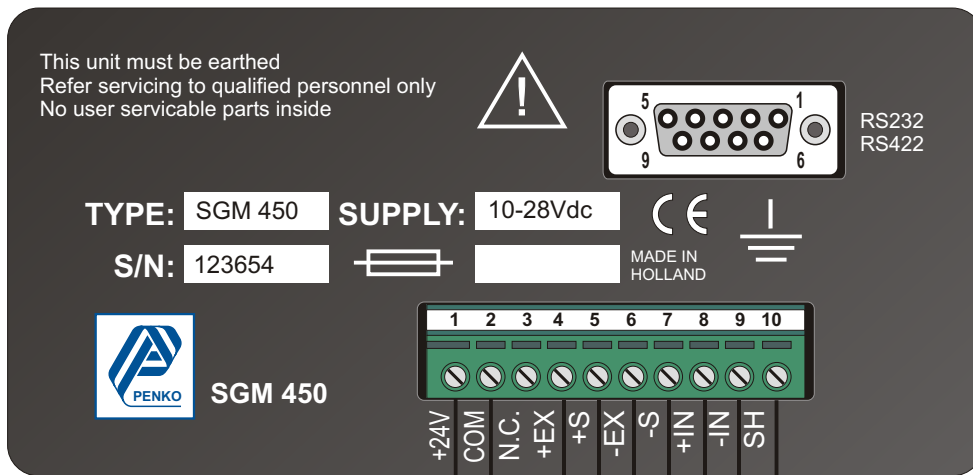

COMMUNICATION PORT
RS232 OR RS422

+24V
Supply +24VDC
COM
Supply 0VDC
N.C.
+ EXCITATION
+ SENSE
- EXCITATION
- SENSE
+ SIGNAL
- SIGNAL
SHIELD

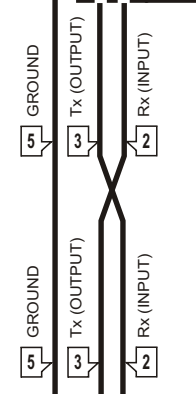
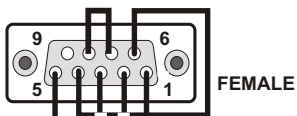
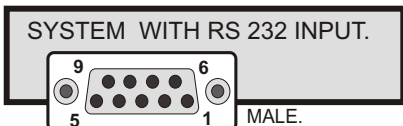

FEMALE SGM450

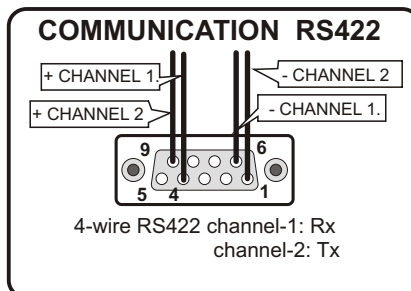
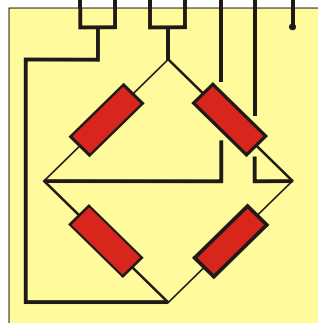

3.2 STATION NUMBER & BAUDRATE SETTINGS COM-PORT SGM450

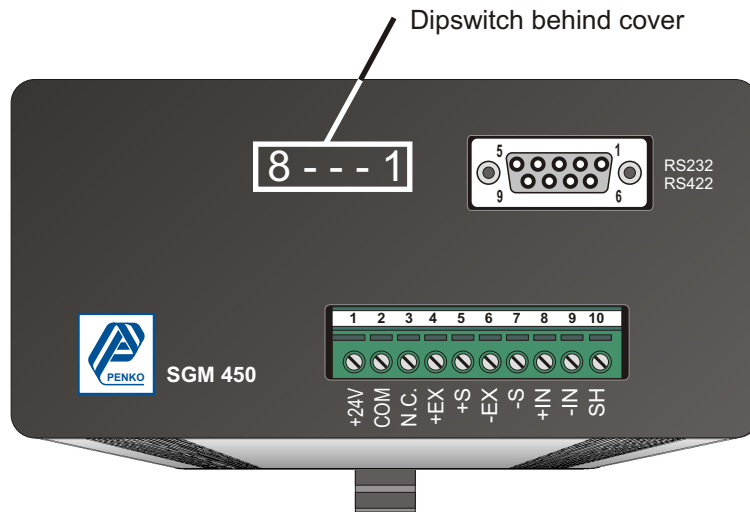

CABINET FOR MOUNTING ON DIN-RAIL

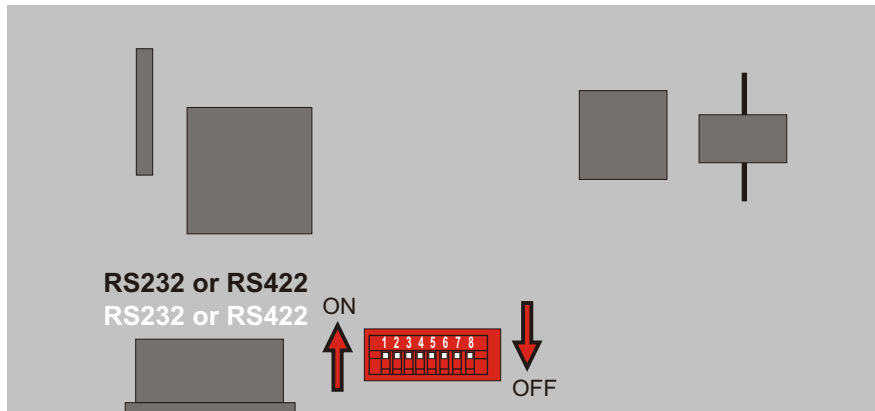

Upper board (component side)

DIPSWITCH SETTINGS FOR COM-PORT RS232 OR Rs422

CHANNEL NUMBER:	DIPSWITCH					
	S1:	S2:	S3:	S4:	S5:	S6:
0	OFF	OFF	OFF	OFF	OFF	OFF
1	ON	OFF	OFF	OFF	OFF	OFF
2	OFF	ON	OFF	OFF	OFF	OFF
3	ON	ON	OFF	OFF	OFF	OFF
4	OFF	OFF	ON	OFF	OFF	OFF
5	ON	OFF	ON	OFF	OFF	OFF
6	OFF	ON	ON	OFF	OFF	OFF
21	ON	OFF	ON	OFF	ON	OFF
37	OFF	OFF	ON	OFF	OFF	ON
63	ON	ON	ON	ON	ON	ON

S1=BINARY-1
S2=BINARY-2
S3=BINARY-4
S4=BINARY-8
S5=BINARY-16
S6=BINARY-32

BAUDRATE SETTING:	DIPSWITCH	
	S7	S8
9600	OFF	OFF
19200	ON	OFF
38400	OFF	ON
115200	ON	ON

3.3 WIRING CONNECTIONS SGM500 (HARDWARE REVISION 1.2)

COMMUNICATION RS422

channel-1: Rx
channel-2: Tx

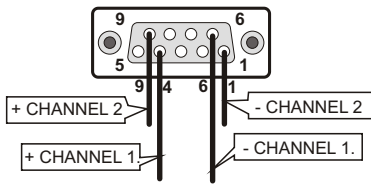

OUTPUTS

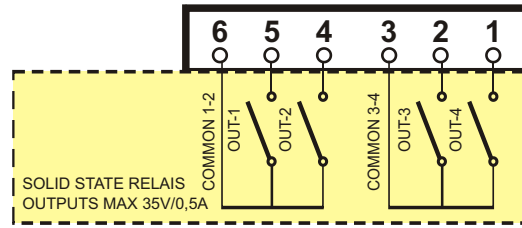

COMMUNICATION RS232

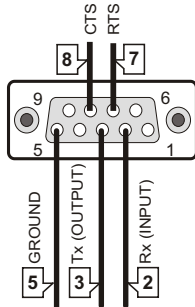

Dip switch setting for SGM500:

Examples:

- SW1=0 SW2=1 =>channel-1
- SW1=1 SW2=1 =>channel-16
- SW1=2 SW2=1 =>channel-32
- SW1=3 SW2=1 =>channel-48
- SW1=4 SW2=1 =>channel-64
- Possible addresses 0-255.
- SW1=0 SW2=A =>channel-10
- SW1=1 SW2=A =>channel-25
- SW1=2 SW2=A =>channel-41
- SW1=3 SW2=A =>channel-57
- SW1=4 SW2=A =>channel-73

SW1 & 2: Device address
(Channel number)

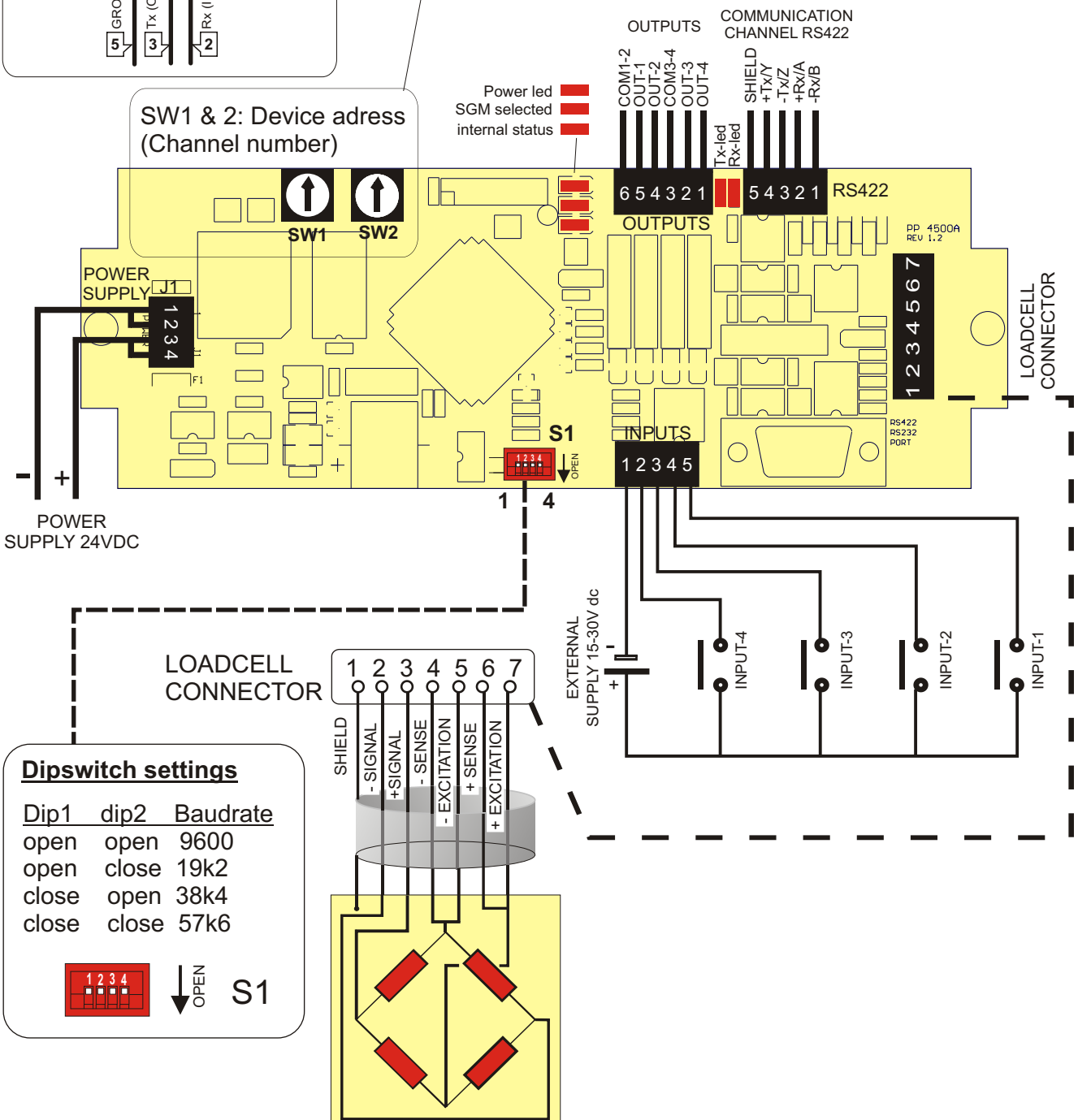

Dipswitch settings

Dip1	dip2	Baudrate
open	open	9600
open	close	19k2
close	open	38k4
close	close	57k6

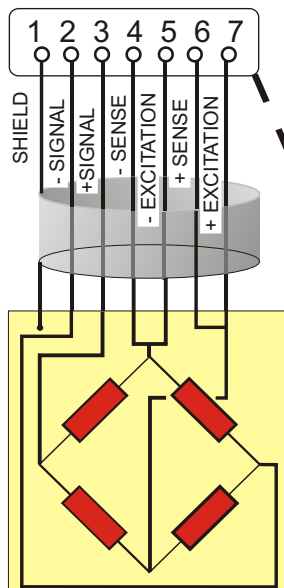

3.4 WIRING CONNECTIONS SGM600

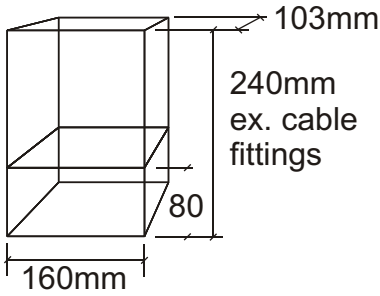

Address of the SGM600
See table at SGM450 for
Channel-setting.

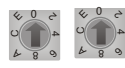

Walking light when SGM600 is
selected, address=0 or
address =255



COMMUNICATION RS422

channel-1: Rx, channel-2: Tx

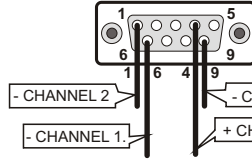

COMMUNICATION RS232

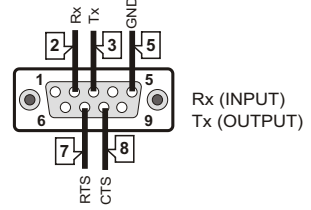

Communication port 9-pole Sub-D RS232 /
RS422
Connections parallel to terminals below.

Communication speed:

Dip-3	Dip-4	Operation:
ON	ON	115k2
OFF	ON	38k4
ON	OFF	19k2
OFF	OFF	9600

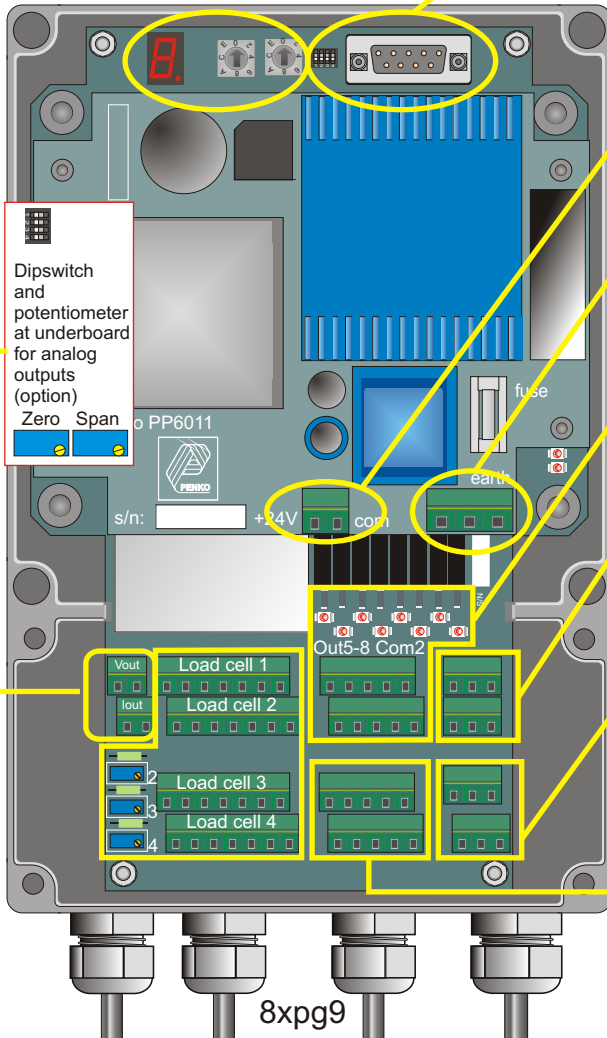

Dipswitch and potentiometer at underboard for analog outputs (option)
Zero Span

Supply 24Vdc for IN-/OUTPUTS
Not stabilized, Max. 100mA.

Power supply 230V~
(24V~ or 24V= optional)

8x Outputs
4 outputs per common
Max. 35V / 0,5A

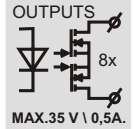

Communicationport RS232
1=Tx, 2=RTS, 3=Gnd
4=Rx, 5=CTS, 6=earth
Connections parallel to 9p sub-D connector

Communicationport RS422
1=-Rx, 2=-Tx, 3=earth
4=+Rx, 5=+Tx, 6=earth
Connections parallel to 9p sub-D connector

8x Inputs 24Vdc
4x inputs per common

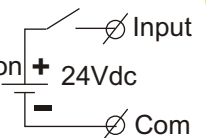

Optional current or
voltage output. See
dipswitch settings for
the setting.

Dipswitch settings:

Dip-1	Dip-2	Operation:
ON	ON	V-out
OFF	ON	4-20mA
ON	OFF	0-20mA
OFF	OFF	0-24mA

Zero Span
When needed fine tuning
for zero and gain.

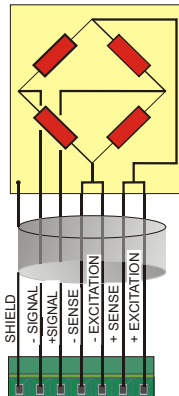

Loadcell connections
Pinning connector 1-4 are identical.
Always use Loadcell connector-1.

Corner correction is sometimes needed to get the same weighing value on each corner of the weigher. Near loadcell connector 2,3 & 4 is placed a resistor of 0 ohm and a potentiometer. With the potentiometer it's possible to reduce the excitation voltage to the loadcell. Remove the resistor of 0 ohm first before trimming the potentiometer. Always connect the loadcell with the lowest weight value at connector-1. Ask Penko for more information
On corner correction.